

# CUSTOM ENGINEERED BEVERAGE SYSTEMS

## Hot Fill (HTST) and UHT

### Batch Bottle Pasteurizers & Chillers

Bottom Line Process Technologies, Inc. offers customized solutions for beverage processing, including self-contained, movable units for maximum flexibility in the lab. Call today to discuss your project.

- Designed to Your Specifications
- Designed for Your Facility
- UHT and HTST
- Batch and Continuous Systems
- Individual Components or Complete Systems
- Safe, Simple and Scalable
- No Steam Required



*HTST Hot Fill Unit with Bottle Filler.  
Simple Operation. Flexible Design.*

*Batch Bottle Pasteurizer.  
Heat & Cool Filled Bottles  
to Your Specification.*



*Self-Contained Batch Bottle Chiller. Chilled Water  
Recirculates to Cool Bottles to Desired Temperature.*

# EFFICIENT AND AFFORDABLE BEVERAGE SAMPLE PREPARATION

Designed with Sanitation in Mind

Equipment can be put on Casters or Built to Specification for Easy Installation and Integration into Facility

Product Rates, Batch Sizes

Continuous - Typical rates 0.5 to 2 litres per minute, depending on customer requirements, available utilities, etc.

Batch - one to 5 litres, can be customized

Materials of Construction

Product contact surfaces - 304 and/or 316 stainless steel

Gasket materials- all FDA approved (i.e., Teflon, UHMW, Silicone, Buna, Viton)

Pumps - Stainless steel and/or FDA approved elastomers (i.e., Tygon, Norprene, Viton, etc.)

All other frames, guards, surfaces - 304 and/or 316 stainless steel, aluminum, polycarbonate  
Teflon, UHMW

No painted surfaces

Electrical Requirements

Generally 208 - 230 volt, 60Hz, 1 phase and/or 110 - 120 volt, 60Hz, 1 phase

Heating loads can be customized to fit the process requirements or the constraints of the electrical service in your lab

Heating Units Available from 2 KW to 10 KW

Water Chilling Units Available from 1/2 ton to 2 tons

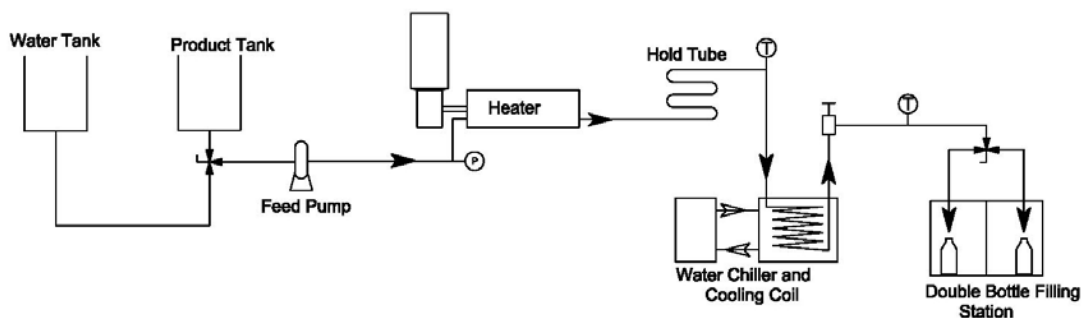

Manufactured By:

**Bottom Line Process Technologies, Inc.**

8034 118th Ave. N.

Largo, FL 33773 USA

Ph/Fax 1.727.548.6484

Toll Free 1.888.834.4552

Represented By:

[www.blp-inc.com](http://www.blp-inc.com)

**BLT**  
INC.  
PROCESS

[info@blp-inc.com](mailto:info@blp-inc.com)